

**LOGICAL DIAGRAM**

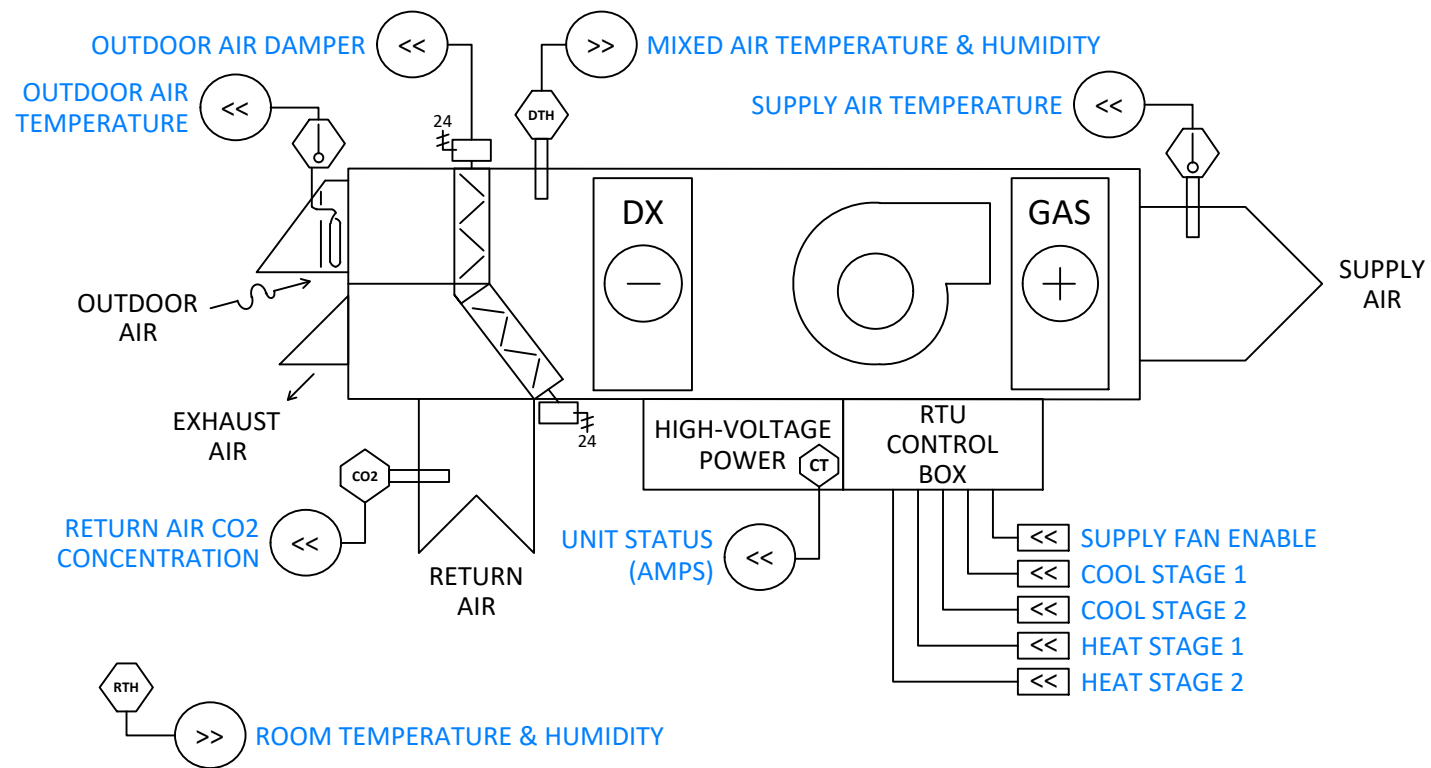

**SEQUENCE OF OPERATION**

THE RTUs WILL USE THE DIFFERENCE BETWEEN THE WEIGHTED AVERAGE CURRENT TEMPERATURE AND THE AVERAGE DESIRED TEMPERATURE FOR LOAD CALCULATIONS. SINGLE ZONE RTUs WILL USE A WEIGHTED AVERAGE OF ONLY ONE ZONE.

**HEATING/ COOLING**

1. WHEN OCCUPANCY BEGINS, THE UNIT WILL START THE SUPPLY FAN.
2. AS DEMAND FOR COOLING INCREASES, ASSUMING ECONOMIZER IS UNAVAILABLE, THE COOLING STAGES WILL STEP UP. WHEN THE DELTA T IS 2°F, BOTH STAGES OF COOLING WILL BE RUNNING.
3. AS DEMAND FOR HEATING INCREASES, THE HEATING STAGES WILL STEP UP. WHEN THE DELTA T IS 2°F, BOTH STAGES OF HEATING WILL BE RUNNING.

**ECONOMIZING**

4. FREE COOLING WILL BE AVAILABLE WHENEVER INDOOR AIR ENTHALPY IS GREATER THAN OUTDOOR AIR ENTHALPY.
5. IF FREE COOLING IS AVAILABLE AND THERE IS COOLING DEMAND, THE OUTDOOR AIR DAMPER WILL MODULATE OPEN UNTIL IT REACHES 100% OR THE MIXED AIR TEMPERATURE FALLS BELOW 50°F. IF THE MIXED AIR TEMPERATURE FALLS BELOW 44°F, THE OUTDOOR AIR DAMPER WILL CLOSE TO MINIMUM POSITION.
6. IF THE OUTDOOR AIR DAMPER IS FULLY OPEN FOR 15 MINUTES AND THE COOLING LOAD DOES NOT DECREASE BY AT LEAST 30% OVER THAT TIME, MECHANICAL COOLING WILL BE ENABLED (SUBJECT TO A MINIMUM OUTDOOR AIR TEMPERATURE LOCKOUT).

**DEMAND CONTROL VENTILATION**

7. WHEN THE RETURN AIR CO2 IS 1000PPM OR GREATER, A MINIMUM OUTDOOR AIR DAMPER POSITION WILL APPLY. THE MINIMUM POSITION WILL INCREASE BY 10% FOR EVERY 100PPM ABOVE THE THRESHOLD (E.G. 10% AT 1100PPM, 100% AT 2000PPM).

**75F COMMISSIONING NOTES:**

- SYSTEM PROFILE WILL BE SET TO "DAB STAGED RTU".
- ENABLE: RELAY 1 (Y1), RELAY 2 (Y2), RELAY 3 (G1), RELAY 4 (W1), AND RELAY 5 (W2)
- CONFIGURE RELAYS AS FOLLOWS: RELAY 1 = COOLING STAGE 1, RELAY 2 = COOLING STAGE 2, RELAY 3 = FAN STAGE 1, RELAY 4 = HEATING STAGE 1, RELAY 5 = HEATING STAGE 2

**Drawing Notes:**

- ①
- ②
- ③



**Project Name:**  
75F DESIGN MASTER  
REV. 1.4

**Project Address:**

**DB:**      **CB:**      **Page:**      **of**

**Drawing:**      DAB STAGED RTU WITH OAO (LOGICAL)