

CENTRAL CONTROL UNIT (CCU)

DESCRIPTION	POINT	TAG	DEVICE RANGE	MFG	PART #
SPARE	TH1		10K TYPE II OR DIGITAL		
SPARE	TH2		10K TYPE II OR DIGITAL		
SPARE	AI1		0-10VDC		
SPARE	AI2		0-10VDC		
COOL STAGE 1	BO1 (Y1)	TSTAT	CC = ENABLE	-	(TO UNIT)
COOL STAGE 2	BO2 (Y2)	TSTAT	CC = ENABLE	-	(TO UNIT)
SUPPLY FAN ENABLE	BO3 (G)	TSTAT	CC = ENABLE	-	(TO UNIT)
HEAT STAGE 1	BO4 (W1)	TSTAT	CC = ENABLE	-	(TO UNIT)
HEAT STAGE 2	BO5 (W2)	TSTAT	CC = ENABLE	-	(TO UNIT)
SPARE	BO6 (O/B)		WET CONTACT		
SPARE	AO1		0-10VDC		
SPARE	AO2		0-10VDC		
SPARE	AO3		0-10VDC		
SPARE	AO4		0-10VDC		
POWER IN	R	TXFR	24VAC (FROM UNIT)	75F	3X-PS-C7X-X
ROOM TEMPERATURE & HUMIDITY	RTS	RTH	3-PIN CABLE (NO LOCAL INTERFACE)	75F	7X-SE-C42K-X
SPARE	USB		USB CONNECTOR		

SMART NODE

DESCRIPTION	POINT	TAG	DEVICE RANGE	MFG	PART #
RETURN AIR CO2 CONCENTRATION	UI1	RACO2	0-10VDC = 0-2000PPM	75F	3X-SE-C21X-X
UNIT STATUS (AMPS)	UI2	AMPS	0-10VDC = 0-150A	75F	3X-HW-C110X-X
OUTDOOR AIR TEMPERATURE	UI3	OAT	°F (10K TYPE II)	75F	3X-SE-C33X-X
SUPPLY AIR TEMPERATURE	UI4	SAT	°F (10K TYPE II)	75F	3X-SE-C29X-X
OA DAMPER CONTROL SIGNAL	AO1	OAD	0-10VDC = 0-100% OPEN	75F	3X-AT-C1X-X
RA DAMPER CONTROL SIGNAL	AO2	RAD	0-10VDC = 0-100% OPEN	75F	3X-AT-C1X-X
SPARE	AO3		0-10VDC / 4-20mA		
SPARE	AO4		0-10VDC / 4-20mA		
SPARE	RELAY 1		DRY CONTACT		
SPARE	RELAY 2		DRY CONTACT		
SPARE	RELAY 3		DRY CONTACT		(FROM UNIT)
SPARE	RELAY 4		24VAC		
POWER IN	POWER IN	24VAC IN	24VAC (FROM UNIT)	-	(FROM UNIT)
MIXED AIR TEMP & HUMIDITY	RTS	DTH	3-PIN CABLE (NO LOCAL INTERFACE)	75F	7X-SE-C16X-X
SPARE	POR				
SPARE	RS-485				

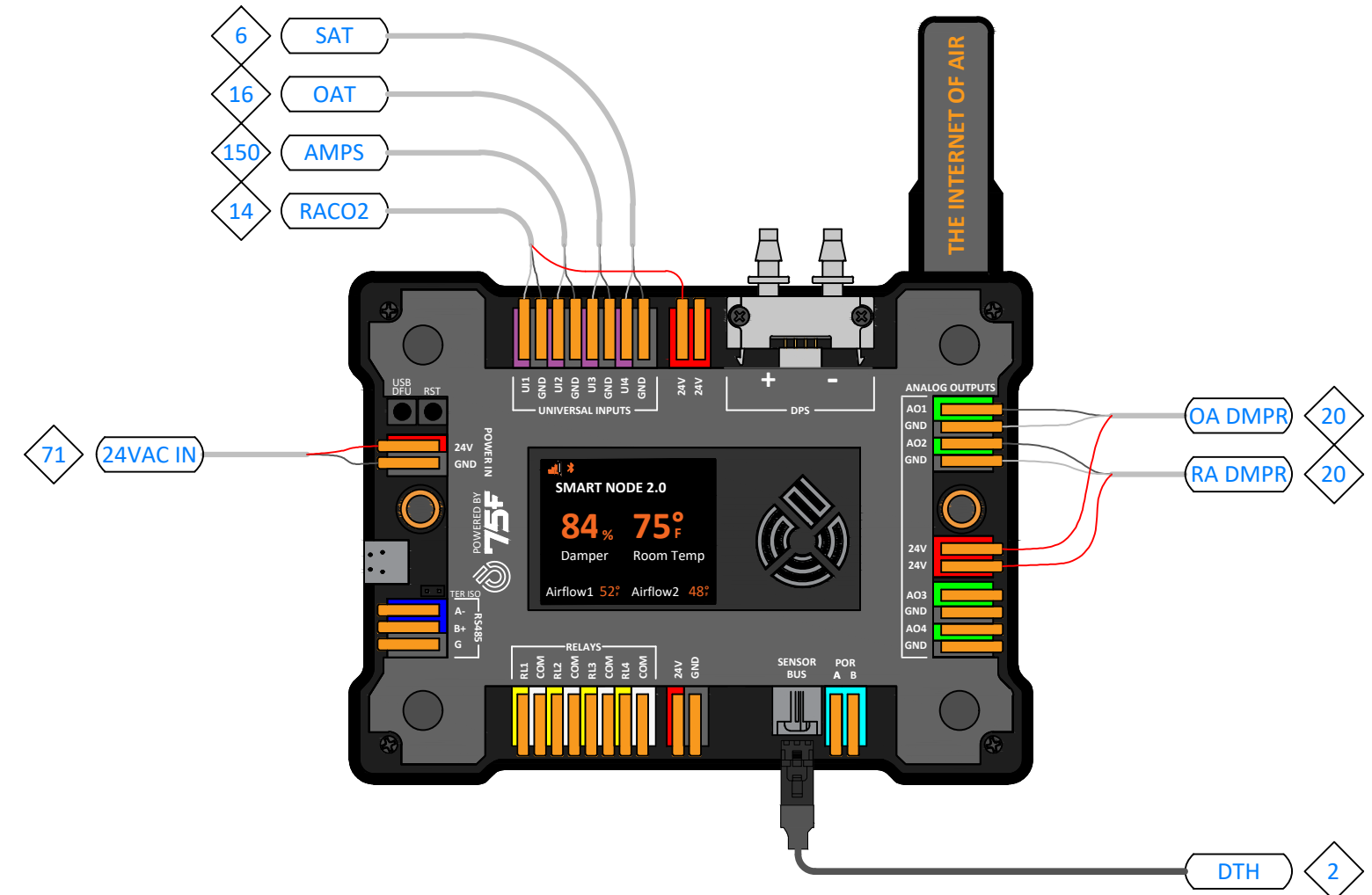
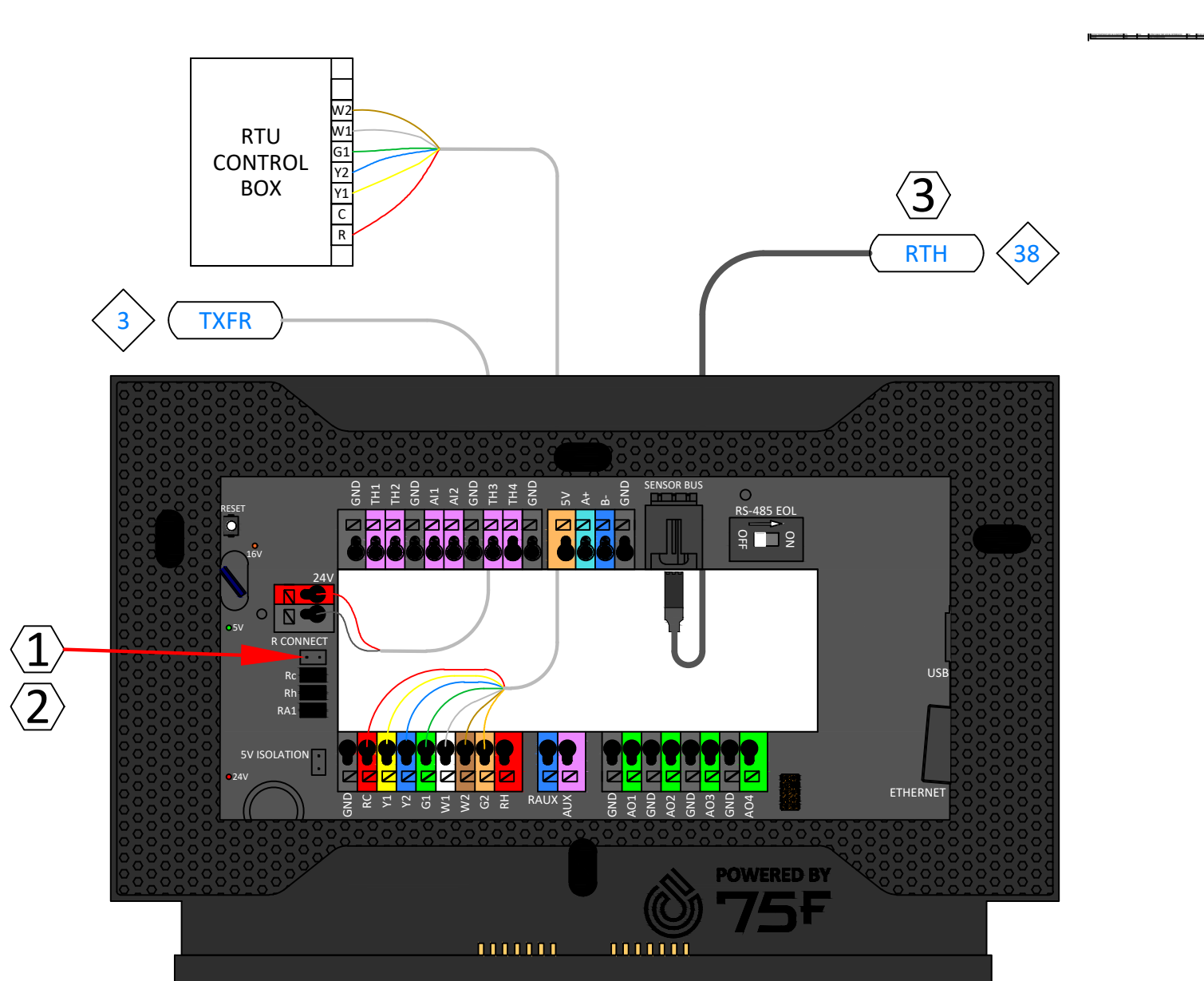

Drawing Notes:

- ① WHEN USING ISOLATED POWER SUPPLY, REMOVE R CONNECT JUMPER. FAILURE TO DO REMOVE WILL VOID WARRANTY.
- ② WHEN USING ISOLATED POWER SUPPLY, DO NOT LAND 24V COMMON FROM RTU T-STAT WIRE
- ③ WALL SENSOR MUST BE INSTALLED IN A LOCATION MOST REPRESENTATIVE THE AVERAGE SPACE CONDITIONS



Project Name:
75F DESIGN MASTER
REV. 1.4

Project Address:

DB: **CB:** **Page:** **of**

Drawing: DAB STAGED RTU WITH OAO (PHYSICAL)