

X.1 - LOGICAL DIAGRAM

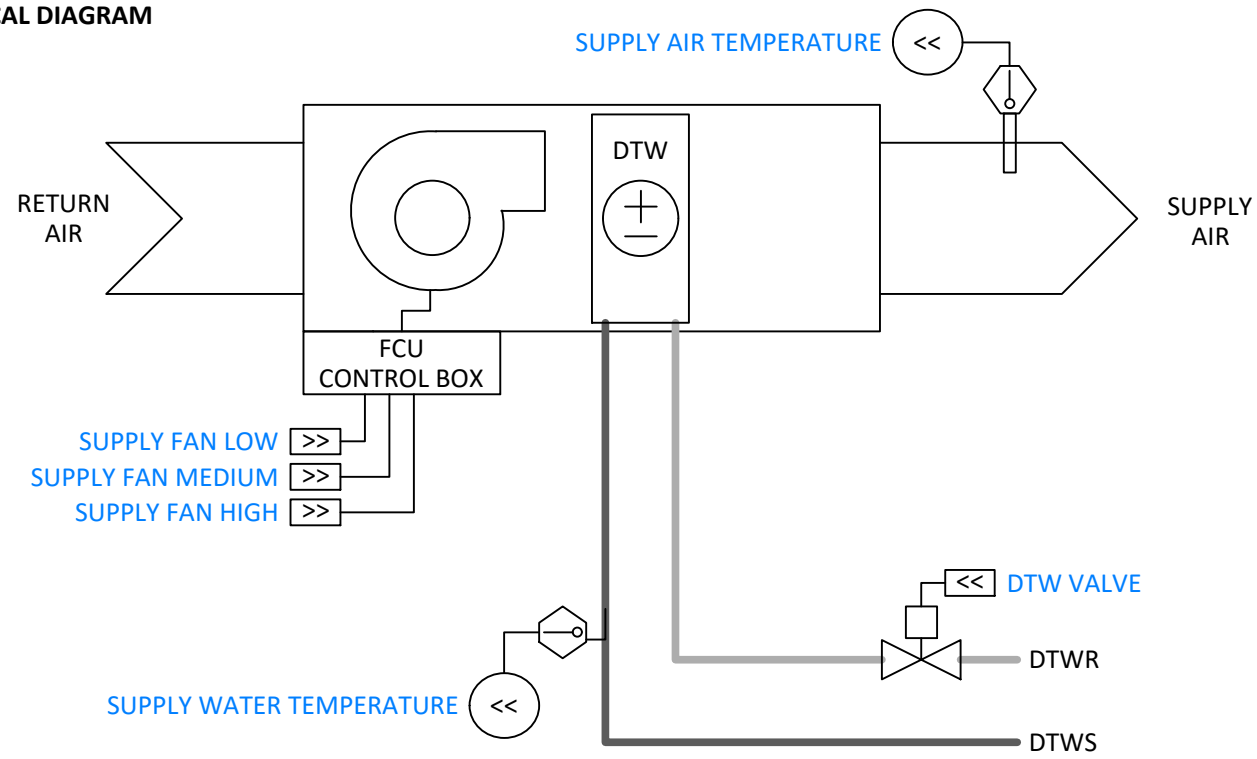

X.2 - POINTS LIST

HYPERSTAT					
DESCRIPTION	POINT	TAG	DEVICE RANGE	MFG	PART #
SPARE	AI1		0-10VDC		
SPARE	AI2		0-10VDC		
SUPPLY AIR TEMPERATURE	TH1	SAT	°F (10K TYPE II)	75F	3X-SE-C29X-X
SUPPLY WATER TEMPERATURE	TH2	SWT	°F (10K TYPE II)	75F	3X-SE-C28X-X
DTW VALVE	Y1	DTW VLV	CC = VALVE OPEN		
SPARE	Y2		CC = ENABLE		
SUPPLY FAN LOW	G1	TSTAT	CC = FAN LOW		
SUPPLY FAN MEDIUM	W1	TSTAT	CC = FAN MEDIUM		
SUPPLY FAN HIGH	W2	TSTAT	CC = FAN HIGH		
SPARE	O/B		CC = ENABLE		
SPARE	AO1		0-10VDC		
SPARE	AO2		0-10VDC		
SPARE	AO3		0-10VDC		
POWER IN	R	TSTAT	24VAC (FROM UNIT)		
SPARE	RTS		3-PIN CONNECTOR		
SPARE	RS485		4-PIN CONNECTOR		

X.4 - SEQUENCE OF OPERATION

THE FAN COIL UNIT (FCU) IS A WEIGHTED AVERAGE OF ONLY ONE ZONE.

HEATING/COOLING

1. UPON OCCUPANCY, THE SUPPLY FAN WILL BE ENABLED.
2. COOLING/HEATING MODE OPERATION IS DETERMINED BY THE CENTRAL PLANT.
3. WHEN THE CENTRAL PLANT IS PROVIDING CHILLED WATER, THE DTW VALVE WILL OPEN WHEN THE CURRENT TEMPERATURE RISES ABOVE THE COOLING SETPOINT (72°F, ADJ.). THE DTW VALVE WILL CLOSE WHEN THE CURRENT TEMPERATURE FALLS AT LEAST 0.5°F BELOW THE COOLING SETPOINT.
4. WHEN THE CENTRAL PLANT IS PROVIDING HOT WATER, THE DTW VALVE WILL OPEN WHEN THE CURRENT TEMPERATURE FALLS BELOW THE HEATING SETPOINT (68°F, ADJ.). THE DTW VALVE WILL CLOSE WHEN THE CURRENT TEMPERATURE RISES AT LEAST 0.5°F ABOVE THE HEATING SETPOINT. IF THE ZONE REQUIRES ADDITIONAL HEATING, THE AUXILIARY HEAT WILL BE ENABLED WHEN THE CURRENT TEMPERATURE IS AT LEAST 3°F BELOW SETPOINT.

75F COMMISSIONING NOTES

- THE SYSTEM PROFILE WILL BE SET TO '2-PIPE FCU'.
- ENABLE: RELAY 1 (Y1), RELAY 3 (G), RELAY 4 (W1), RELAY 5 (W2), TH1, AND TH2.

