

X.1 - LOGICAL DIAGRAM

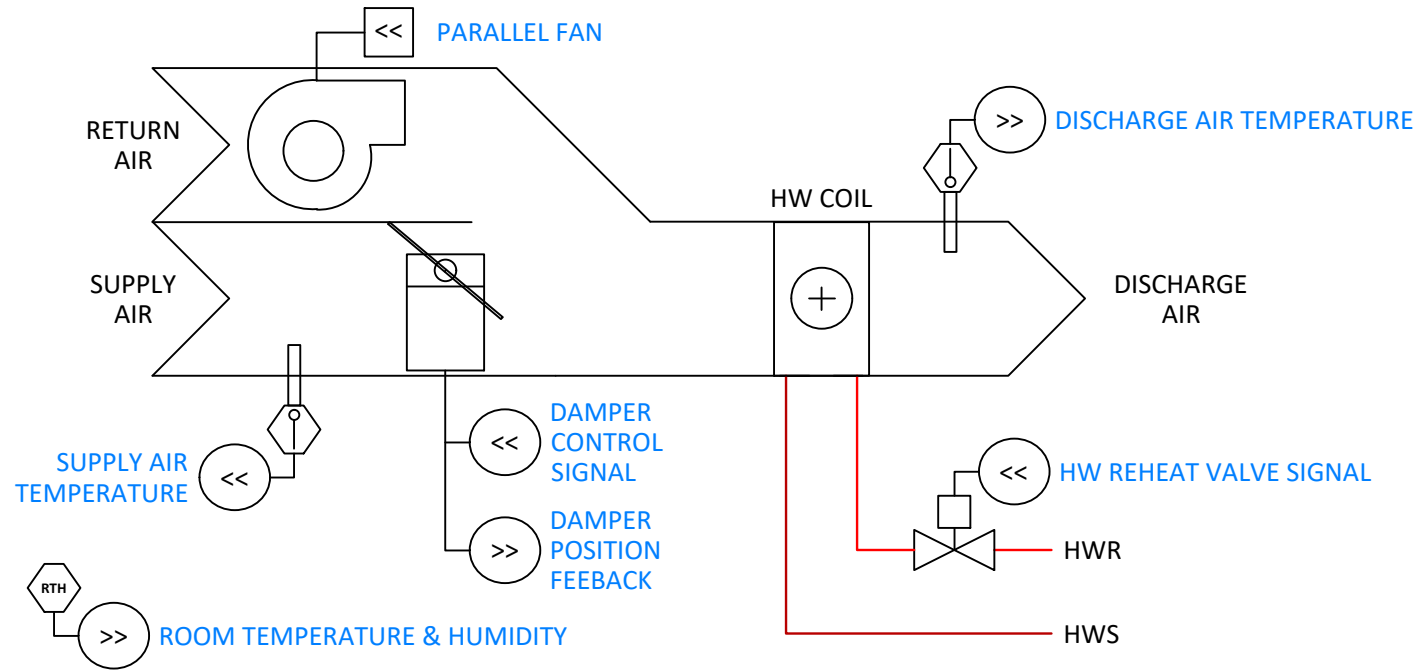

X.2 - POINTS LIST

SMART NODE					
DESCRIPTION	POINT	TAG	DEVICE RANGE	MFG	PART #
DAMPER POSITION FEEDBACK	AI1	DMPR	0-10VDC FEEDBACK = 0-100% OPEN	75F	7X-AT-C6X-X
SPARE	AI2		0-10VDC		
DISCHARGE AIR TEMPERATURE	TH1	DAT	°F (10K TYPE II)	75F	3X-SE-C29X-X
SUPPLY AIR TEMPERATURE	TH2	SAT	°F (10K TYPE II)	75F	3X-SE-C29X-X
DAMPER CONTROL SIGNAL	AO1	DMPR	0-10VDC SIGNAL = 0-100% OPEN	75F	7X-AT-C6X-X
HW REHEAT VALVE SIGNAL	AO2	RHT	2-10VDC = 0-100% OPEN	75F	7X-AT-C4X-X
SPARE	RELAY 1		DRY CONTACT		
PARALLEL FAN	RELAY 2	FAN	CC = ENABLE	75F	3X-RB-C3X-X
POWER IN	POWER IN	24VAC IN	24VAC (BY OTHERS)	-	(BY OTHERS)
SPARE	POWER OUT		24VAC		
SPARE	DAMPER 1		NOT USED		
SPARE	DAMPER 2		NOT USED		
ROOM TEMP & HUMIDITY	RTS	RTH	3-PIN CABLE (NO LOCAL INTERFACE)	75F	7X-SE-C42K-X
SPARE	RS-485		4-PIN CONNECTOR		

X.3 - PHYSICAL DIAGRAM

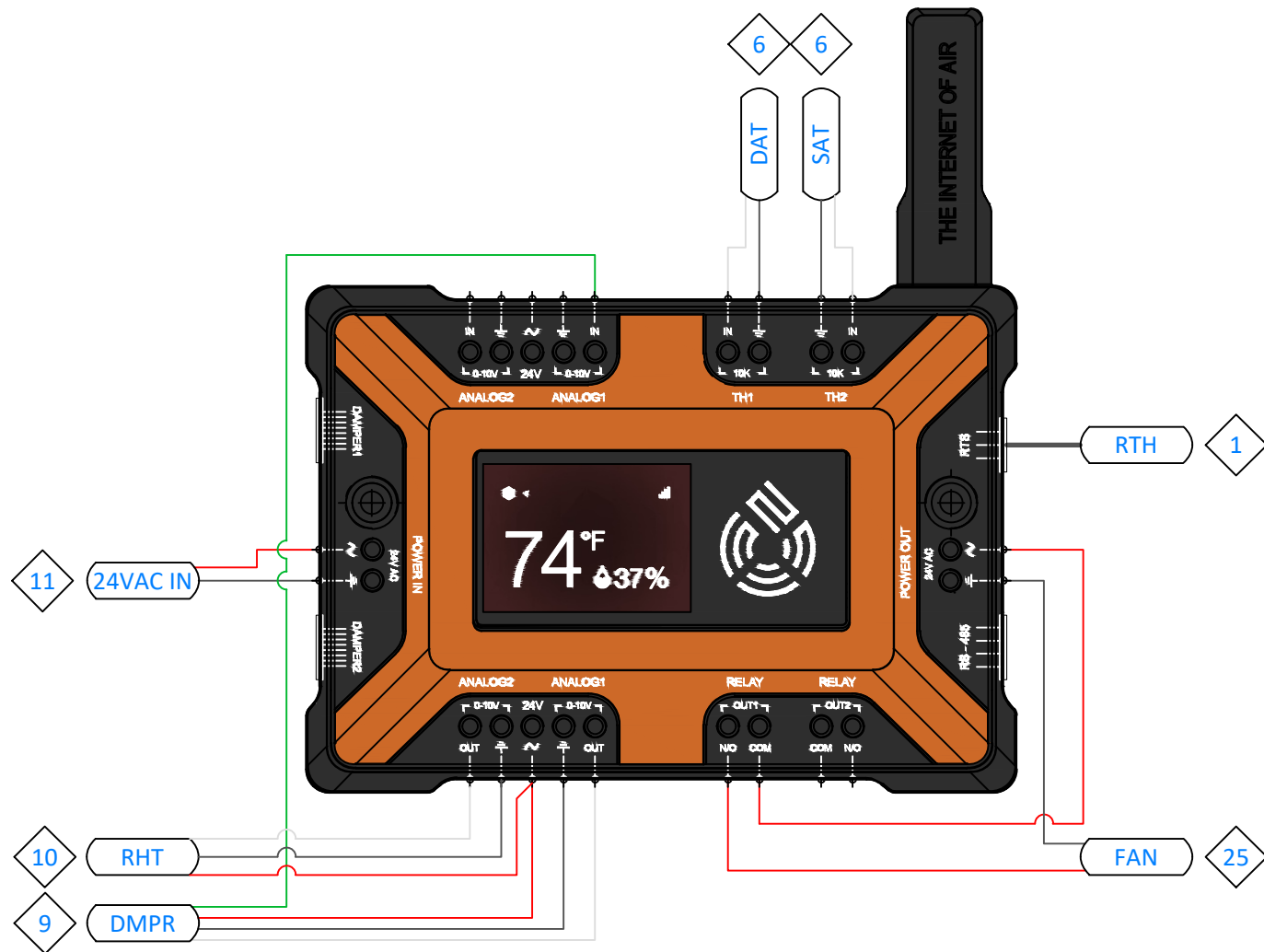

X.4 - SEQUENCE OF OPERATION

THE CONTROLLER MODULATES THE SUPPLY AIR DAMPER AND HOT WATER VALVE TO MAINTAIN THE ROOM TEMPERATURE AT SETPOINT ACCORDING TO ASHRAE GUIDELINE 36.

COOLING

WHEN THE SYSTEM IS COOLING AND THE ZONE ALSO REQUIRES COOLING, THE DAMPER WILL MODULATE FROM ITS MINIMUM POSITION WHEN THERE IS NO LOAD TO MAXIMUM POSITION WHEN THE LOAD IS 100%. REHEAT WILL NOT ENGAGE.

HEATING

WHEN THE ZONE REQUIRES HEATING, THE PARALLEL FAN WILL BE ENABLED.

WHEN THE SYSTEM IS IN COOLING AND THE ZONE REQUIRES HEATING, THE DAMPER WILL MODULATE TO ITS MINIMUM POSITION UNTIL THE CURRENT DISCHARGE AIR TEMPERATURE (DAT) REACHES ITS MAXIMUM SETPOINT. THE DAT SETPOINT IS RESET ACCORDING TO THE HEATING LOAD IN THE SPACE. WHEN THE ZONE IS AT 50% HEATING LOAD, THE DAT SETPOINT WILL BE AT ITS MAXIMUM. ONCE THE DAT SETPOINT IS RESET TO ITS MAXIMUM, THE DAMPER WILL MODULATE TOWARD ITS MAXIMUM POSITION AS THE ZONE VARIES BETWEEN 51-100% HEATING LOAD. IF THE TEMPERATURE DIFFERENCE ACROSS THE REHEAT COIL IS LESS THAN 9°F (ADJ.), THE DAMPER WILL REMAIN AT ITS MINIMUM POSITION.

WHEN THE SYSTEM IS IN HEATING AND THE ZONE REQUIRES HEATING, THE DAMPER WILL MODULATE TO NEAR ITS MAXIMUM POSITION UNTIL THE ZONE IS SATISFIED. ONCE ANY ZONE IS SATISFIED, THE SYSTEM WILL STOP PROVIDING HEAT AND WILL SWITCH BACK INTO COOLING.

75F COMMISSIONING NOTES

- EACH OF THE ZONE CONTROLS SHOULD BE PAIRED AS A 'VAV REHEAT - PARALLEL FAN' ZONE PROFILE.
- FIRST DAMPER TYPE WILL BE SET TO '0-10VDC DAMPER' CONTROL.
- DAMPER SIZE AND SHAPE WILL BE DETERMINED BY THE INSTALLER.
- REHEAT OPTION WILL BE SELECTED. THE REHEAT CONTROL OUTPUT WILL BE CHANGED TO 'ANALOG 2' AND CONTROL WILL BE SET TO '2-10VDC'.
- RELAY 1 WILL BE SET TO 'PARALLEL FAN'.

Drawing Notes:

- ①
- ②
- ③



Project Name:
75F DESIGN MASTER
REV. 1.4

Project Address:

DB: **CB:** **Page:** **of**

Drawing: PARALLEL FPVAV (HW) WITH RTH